

Chroma Systems Solutions, Inc.

Equivalent Series Resistance (ESR) of Capacitors

11025 LCR Meter

Keywords: Equivalent Series Resistance, Capacitors

Equivalent Series Resistance (ESR) of Capacitors

Title:

Product Family: **11025 LCR Meter**

Abstract

Questions continually arise concerning the correct definition of the ESR (Equivalent Series Resistance) of a capacitor and, more particularly, the difference between ESR and the actual physical series resistance (which we'll call R_s), the ohmic resistance of the leads and plates or foils. The definition and application of the term ESR has often been misconstrued. We hope this note will answer any questions and clarify any confusion that might exist. Very briefly, ESR is a measure of the total lossiness of a capacitor. It is larger than R_s because the actual series resistance is only one source of the total loss (usually a small part).

The Series Equivalent Circuit

At one frequency, a measurement of complex impedance gives two numbers, the real part and the imaginary part: $Z = R_s + jX_s$. At that frequency, the impedance behaves like a series combination of an ideal resistance R_s and an ideal reactance X_s (Figure 1).

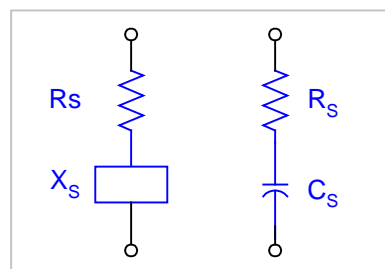

Figure 1: Equivalent Series Circuit Representation

If X_s is negative, the impedance is capacitive and the general reactance can be replaced with a capacitance of:

$$C_s = \frac{-1}{\omega X_s}$$

We now have an equivalent circuit that is correct only at the measurement frequency. The resistance of this equivalent circuit is the equivalent series resistance

$$\text{ESR} = R_s = \text{Real part of } Z$$

Add the Dissipation FACTOR

If we define the dissipation factor D as $D = \frac{\text{energy lost}}{\text{energy stored}} = \frac{\text{Real part of } Z}{(-\text{Imaginary part of } Z)}$

$$\text{Then } D = \frac{R_s}{(-)X_s} = R_s \omega C = (\text{ESR}) \omega C$$

If one took a pure resistance and a pure capacitance and connected them in series, then one could say that the ESR of the combination was indeed equal to the actual series resistance. However, if one put a pure resistance in parallel with a pure capacitance (Figure 2a), the ESR of the combination is

$$\text{Real part of } Z = \text{Real part of } \frac{1}{\frac{1}{R_p} + j\omega C_p} = \frac{R_p}{1 + \omega^2 C_p^2 R_p^2}$$

as illustrated in Figure 2b. From Figure 2a, however, it is obvious that there is no actual series resistance in series with the capacitor.

$$R_{as} = 0$$

But $\text{ESR} > 0$

Therefore $\text{ESR} > R_{as}$

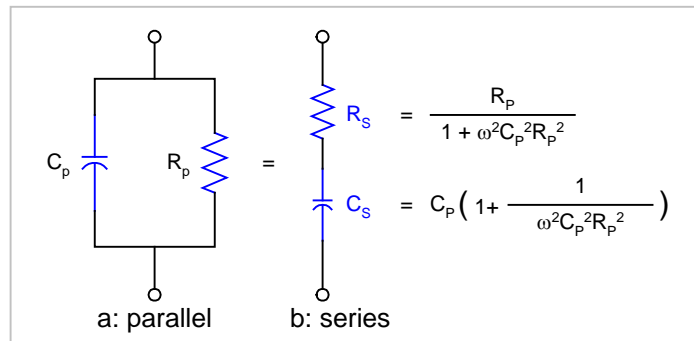

Figure 2: Series and Parallel Equivalent Circuits

Chroma Systems Solutions, Inc. manufactures a wide variety of LCR meters designed for accurate measurements of C, Df and ESR. The design of the Chroma 11025, has been specifically optimized for high speed, low ESR measurements on tantalum and other types of capacitors. Fast settling time and quick open/short recovery significantly reduce test times especially on capacitors greater than 100 μ F at 120Hz. The 11025 Low ESR Capacitance Meter performs most impedance measurements (C, Df, ESR, Z, R, X, L Q, Y, G, B, θ and DCR) over a frequency range of 100Hz – 100kHz. Actual voltage and current is measurable across the DUT.

The ESR of a Real Capacitor

Actual capacitors have three main sources of loss:

1. **Actual series resistance:** There is some resistance in the leads and plates or foils. This is the resistance of conductors and is always low. It causes a power loss $I^2 R_s$ where I is the current flowing in the capacitor. This causes $D_1 = \omega R_s C$

2. **Leakage resistance:** There is some actual parallel resistance due to leakage current in the capacitor. We'll call this R_L . ~~Resistance of the~~ Resistance of the capacitor at DC and it is a high resistance. For plastic capacitors it can be 10^{12} ohms (G Ω) or higher. It causes a loss of E^2/R_L where E is the applied (rms) voltage and $D_2 = \frac{1}{\omega R_L C}$. This loss is usually negligible except at very low frequencies.

3. **Dielectric loss:** This is due to two phenomena molecular polarization and interfacial polarization (dielectric absorption). It is not the purpose of this note to discuss its cause, but only its effect. It causes a D that can change with frequency in most any manner that is not abrupt. It acts neither as a

series resistance, nor as a parallel resistance that would pass DC. One model is a parallel resistance, R_D , which is variable with frequency, with DC blocked by a large series capacitance (C_B) as illustrated in Figure 3.

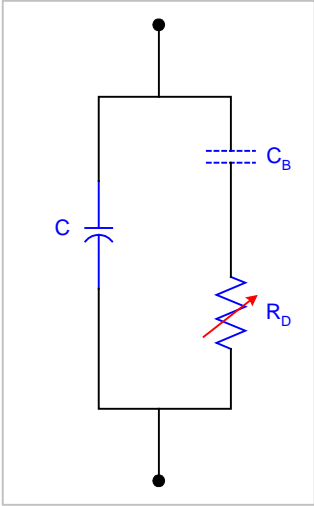

Figure 3: Parallel Resistance

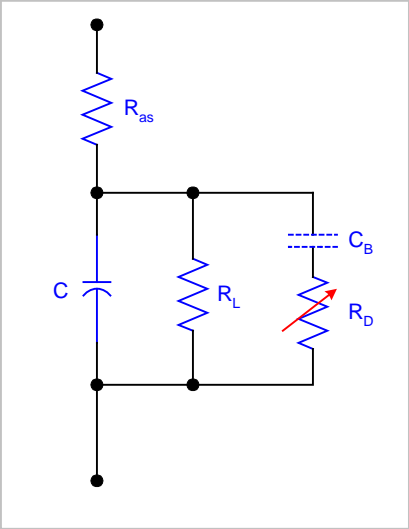

Figure 3: Parallel Resistance

If the series C were infinite, the D would be $D_3 = \frac{1}{\omega R_D C}$ but it must be remembered that it is not inversely proportional to ω because R_D changes with frequency.

All three sources of loss are illustrated in Figure 4. This circuit would have a total dissipation factor equal to $D_1 + D_2 + D_3$.

For the circuit in Figure 4, the total dissipation factor is

$$D = D_1 + D_2 + D_3 = \omega R_{as} C + \frac{1}{\omega R_L C} + \frac{1}{\omega R_D C}$$

Figure 5 illustrates a general plot of this combination series and parallel resistance in a capacitance measurement.

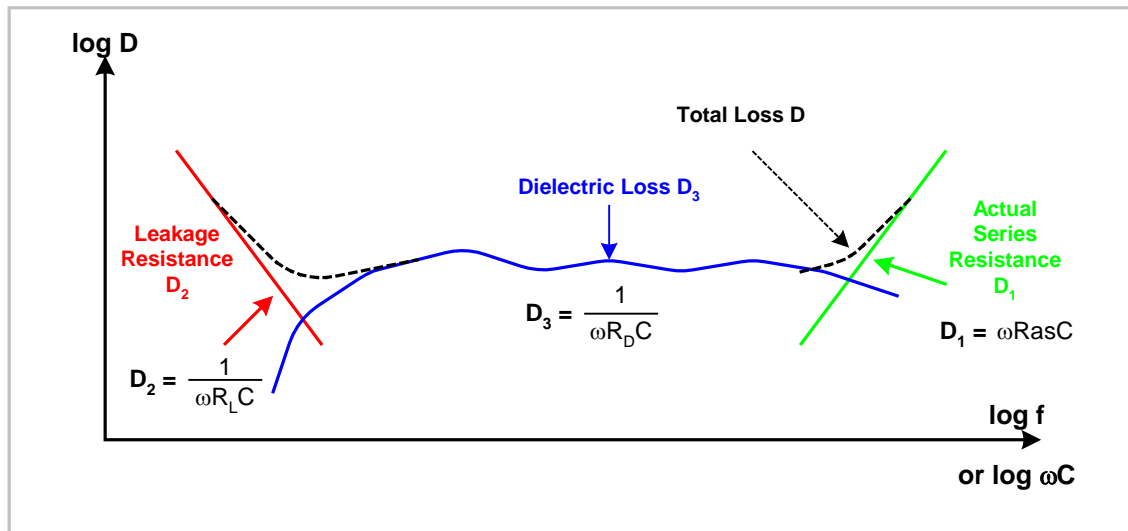

Figure 5: Total Dissipation Factor Plot

At any given frequency we could measure the real part of the impedance, R_s , or measure C and D and calculate it

$$R_s = \text{ESR} = \frac{D}{\omega C} = \frac{D_1 + D_2 + D_3}{\omega C}$$

Therefore $\text{ESR} = R_s + \frac{1}{\omega^2 C^2 R_L} + \frac{1}{\omega^2 C^2 R_D}$ and thus $\text{ESR} > R_s$, always.

Usually, ESR is very much larger than R_s . However, when ωC is large at high frequencies, high capacitances or some combination, the actual series resistance can cause the largest part of the total D . (See plot.) For very large capacitors (like 0.1F), ESR can be very nearly equal to the actual series resistance even at low frequencies (such as 120 Hz). For most capacitors at low frequencies, the actual series resistance is only a small part of ESR .